

Note: To calculate the total spreader weight (including ice control material); add the empty spreader weight plus the ice control material and spreader accessories.

3. Recommended Fastener Torques:

Maintain all fastener torques as shown in the following table. Failure to do so may cause injury to persons.

	SAE GRADE 2 FT-LBS	SAE GRADE 5 FT-LBS
1/4-20	6	9
5/16-18	11	18
3/8-18	19	31
3/8-24	24	46
7/16-14	30	50
1/2-13	45	75
9/16-12	66	110
5/8-11	93	150

4. Engine Oil (gas models) and Gearbox Oil (all models):

The engine crankcase of gasoline powered spreaders is filled with 1 quart of SAE 5W-30 motor oil at the factory. The gearbox of any spreader is filled with SAE 90 gear lubricant at the factory.

WARNING

Verify that the above oil viscosity meets your operating temperature requirements. If not, empty and refill with the proper viscosity oil. Before starting spreader, check that the engine crankcase and gearbox are filled to the proper level with lubricant.

General Safety Precautions

WARNING

Observe the following Safety Precautions before, during and after operating this spreader. By following these precautions and common sense, possible injury to persons and potential damage to this machine may be avoided.

- Read this entire Owner's Manual before operating this spreader; this includes the engine Operator's Manuals for gas powered versions as well.
- Read all safety decals on the spreader before operating the spreader.
- Check to make sure all safety guards are securely mounted into place before operating your spreader.

- Verify that all personnel are clear of the spreader spray area before starting or operating this spreader.
- Keep all loose clothing, hair, jewelry and limbs clear of the spreader before starting or operating this spreader.
- Do not over-load your vehicle beyond payload limits.
- Do not perform any service operation on the spreader while it is running.
- Do not climb on or into the spreader during operation.
- Do not ride on the spreader while the vehicle is in motion.
- Make sure the spreader is securely fastened to the vehicle.
- Do not operate a spreader that is in need of maintenance or repair.

Safety Precautions – Gas Powered Models

- On gas powered models, make sure the engine cover is securely fastened to the spreader before operating the spreader.
- On gas powered spreader versions, never lay tools or equipment on top of the 12V DC battery as this could accidentally ground the positive (+) battery terminal. Grounding the battery could result in electrical shock, burns or damage to the vehicle or equipment.
- Always disconnect the battery before removing or replacing any electrical component.
- A charging battery gives off gases that can explode if touched by a spark or flame. Cover the top of the battery with electrically non-conductive material to keep sparks away from battery gases.
- If the spreader must be operated with the spreader battery disconnected, insulate the positive (red) battery cable and red wire from the engine alternator with electrical tape.

General Installation Instructions – All Models

1. Mounting the Spreader onto the Vehicle:
 - Remove the tailgate from the vehicle if applicable.
 - Lift the spreader using the (4) lifting loops in the corners of the hopper.

⚠ WARNING

The lifting device must be adequately rated to lift a payload equal to or greater than the spreader weight. See page 1 for spreader weights. Empty spreader before lifting.

- Keeping the spreader elevated off the vehicle with lumber helps with removal of material that accumulates under the spreader during operation. Place lumber under the side gussets and central rails of the spreader.
- Center the spreader in the vehicle with the end of the spreader about 14" beyond the back end of the vehicle.
- Bolt the spreader through the lumber and into the vehicle frame using the holes located in each of the side gussets. Use 1/2" SAE grade 5 hardware.
- The spreader may be further secured to the vehicle by using appropriate tie-down straps from the spreader to the vehicle's factory installed anchor points.
- Verify with the vehicle's manufacturer that the factory installed anchor points are designed for tie-down of such load.
- Periodically check that the spreader mounting hardware is securely tightened.

Control Box & Vehicle Wiring Harness Installation - Gas Powered Models.

Note: The following instructions show how to install the spreader so that the engine will draw power to start the engine from a dedicated battery located on the spreader.

1. Vehicle Wiring Installation

Cab Control Box

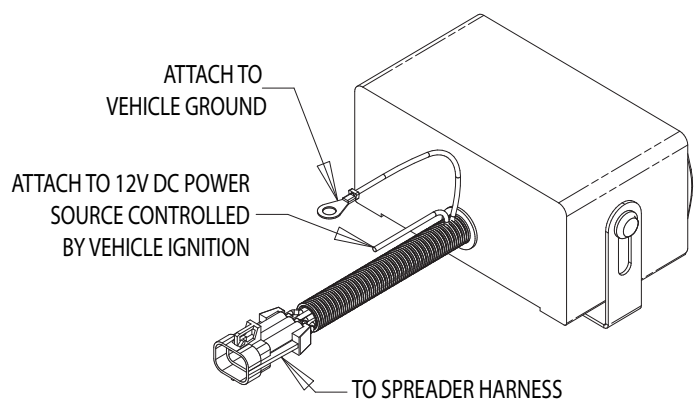

- Determine a wiring path for the vehicle wiring harness.

⚠ WARNING

Do not drill holes into fuel tanks, fuel lines, through electrical wiring, etc that may be damaged by drilling.

- Mount the control box in a convenient location in the truck cab.

⚠ WARNING

Do not install control box in the vehicle's airbag deployment area. Refer to the vehicle's manual for airbag deployment area.

- Connect the green wire from the vehicle wiring harness to a known good vehicle ground.
- Connect the stripped end of the red wire to an accessory wire terminal that is controlled by the vehicle's ignition switch.

2. Spreader Wiring Installation

- Attach the terminal end of the black (negative) battery cable to the negative terminal (marked "-") on the battery.
- Connect the terminal end of the red (positive) battery cable to the positive terminal (marked "+") on the battery.
- Verify that the Ignition Switch in Control Box is in the "OFF" position prior to completing next step.
- Connect the spreader and vehicle wiring harnesses to each other.

Spreader Operation - Gas Powered Models

Note: Before starting the gas spreader engine follow all safety precautions.

Cab Control Box Functions:

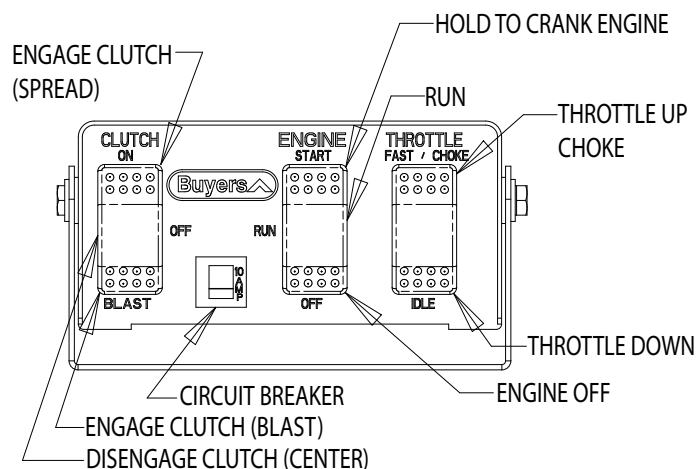

1. Clutch Switch: The clutch switch is a three position switch with the following functions:

- "OFF" position: While in this position, with the engine running, the spreader feed chain and the spinner disk will not rotate and therefore the spreader will not spread ice control material.
- "ON" position: While in this position, the spreader feed chain and the spinner disk will rotate and material will be dispensed when the engine is running.
- "BLAST" position: While in this position with the engine running, the spreader feed chain and the spinner disk will spin. The switch must be held down in the "BLAST" position to activate this function.

2. Ignition Switch: The ignition switch is a three position switch with the following functions:

- "OFF" position: While in this position, 12V DC power is shut off to the spreader. To turn off the spreader, turn the switch to this position.
- "ON" position: While in this position, 12V DC power is turned on to the spreader.
- "START" position: While holding in this position, the spreader's engine starter is activated.

3. Throttle Switch: The throttle switch is a two position switch with the following functions:

- "CHOKE/FAST" position: While in this position, the engine speed will gradually increase until the engine linkage reaches its choke position.
- "IDLE" position: While in this position, the engine speed will gradually decrease.

4. Starting the Gas Engine

- Verify that the clutch switch and ignition switch on the cab control box are in the "OFF" position.
- Turn the vehicle's ignition to the "ON" position.
- Turn the spreader's ignition switch to the "ON" position.
- Press the throttle switch on the cab control box to the "Idle" position and hold for approximately two seconds.
- Hold the ignition switch in the "START" position.
- While the engine is cranking, press and hold the throttle switch to the "CHOKE/FAST" position.
- Release the ignition and throttle switches when the engine starts.
- After the engine starts, press and hold the throttle switch to the "IDLE" position to release the choke (hold switch for 1/2-1 seconds).

5. Stopping the Engine

- Reduce engine RPM by holding throttle switch to the "IDLE" position for 2-3 sec.
- To stop the engine, press the ignition switch to the "OFF" position.

Clutch Operation - Gas Powered Models

- Start the engine & adjust the speed to slightly above idle.
- Push the clutch switch into the "ON" position.
- Increase the engine RPM by pressing the throttle switch to the "CHOKE/FAST" position.
- It is recommended that the clutch only be engaged

at the lowest possible speed without stopping the engine. This practice will prevent premature spinner chain failure and chain tension loss.

- Do not repeatedly use the "Blast" function. Using this function often, will prematurely wear the clutch and flex coupler and promote component failure.

Spinner Chute Installation Instructions - Gas Powered Models

1. Mounting the Gas Spinner Chute Assembly

- Remove the chain guard by first removing the four (4) 1/4-20 X 3/4" hex head bolts, lock washers, and nuts.
- Attach the Spinner Chute Assembly to the gas powered spreader using the four (4) 1/2-13 x 1.25 hex head screws, flat washers, lock washers, and nuts. The flat washers are to be placed over the slots in the sill extensions. Push the chute assembly forward towards the cab of the vehicle and loosely attach the hardware. Do not tighten the fasteners at this time.
- Install the roller chain between the spinner chute sprocket and the gearbox sprocket. Make sure both sprockets are horizontally in line with one another. If the sprockets are out of alignment, adjust the height of the gearbox sprocket to correct the alignment. Install the roller chain master link.
- To adjust the roller chain tension, pull the spinner chute assembly away from the rear of the vehicle to take up slack in chain then tighten chute fasteners. The correct chain tension should allow a 5/16" deflection midway between both chain sprockets. If additional adjustment is needed, loosen the spinner shaft bearing bolts and slide the shaft away from the gearbox sprocket. Be sure to maintain the vertical alignment of the spinner shaft and bearings before tightening the hardware.
- Replace the chain guard using the four (4) 1/4-20 X 3/4" hex head bolts, lock washers, and nuts.
- Tighten all hardware to the recommended torque

CAUTION

Do not over-tension either roller chain. Over-tensioning can cause damage to bearings, roller chain, sprockets, or the engine.

specifications as shown in this manual.

Spinner Chute Installation Instructions - Hydraulic Models

1. Mounting the Hydraulic Spinner Chute Assembly

- Install the hydraulic spinner chute assembly by simply engaging the (4) spring loaded plungers into the corresponding holes in the spreader frame.

Spinner Chute Assembly Operation – All Models

- The spread pattern and the amount of material dispensed will depend on the following factors:
 - Engine RPM.

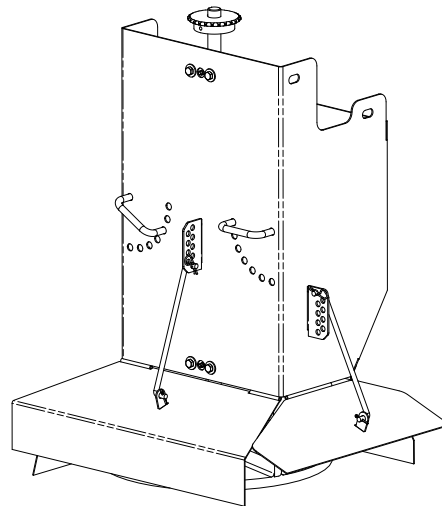

Gasoline Chute

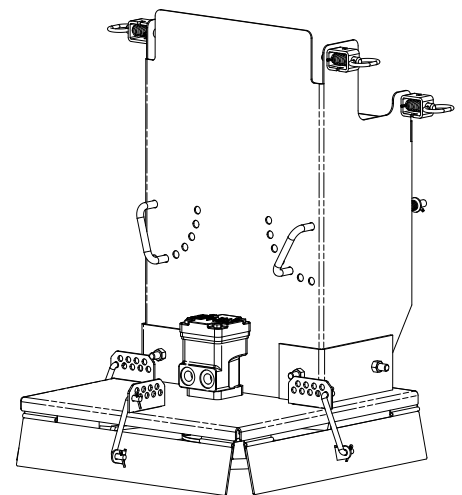

Hydraulic Chute

- Feed gate door position.
- Baffle settings.
- Keep the following rules in mind:
 - Increasing the engine RPM will increase the speed of the conveyor and therefore

amount of material going into the spinner.

- Decreasing the engine RPM will decrease the speed of the conveyor and therefore amount of material going into the spinner.
- Opening or closing the feed gate door will determine the amount of material dropping onto the spinner for any conveyor speed.

Below are illustrations that show the baffles effect on the spread pattern as viewed from the top of the spinner disk.

Installation Instructions - Hydraulic Models

1. During assembly take precautions to keep all hydraulic components as clean as possible.

Internal Baffle Adjustment

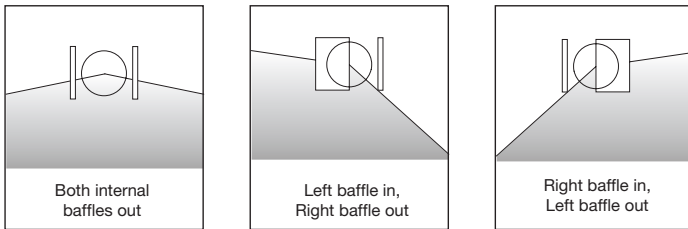

External Baffle Adjustment

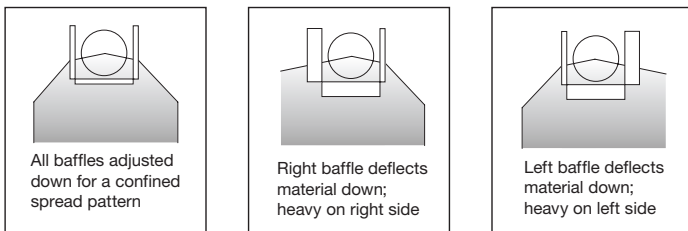

2. Allow enough hose length to prevent kinking and stretching of the hoses and to permit raising the dump body. Support long hoses with wire ties or clamps.

3. Protect hoses from wear caused by sliding and/or vibration.

4. For proper rotation of conveyor chain and spinner motors, hoses may be reversed. The spinner rotates clockwise when looking down from the top.

Note: Use of a pipe joint sealant compatible with hydraulic oil is recommended for all screw fittings.

5. Use swivel type hose ends to connect hoses to flow valve. Damage to valve body may occur if the fittings in flow valve are over tightened.

6. A 10 micron return line filter is recommended to protect the pump, valve, and motors from wear causing contamination.

Spreader Operation - Hydraulic Models

Initial Priming and Inspecting of the System

1. Use high grade non-foaming hydraulic oil to fill reservoir about 3/4 full.

Hydraulic Plumbing Diagram

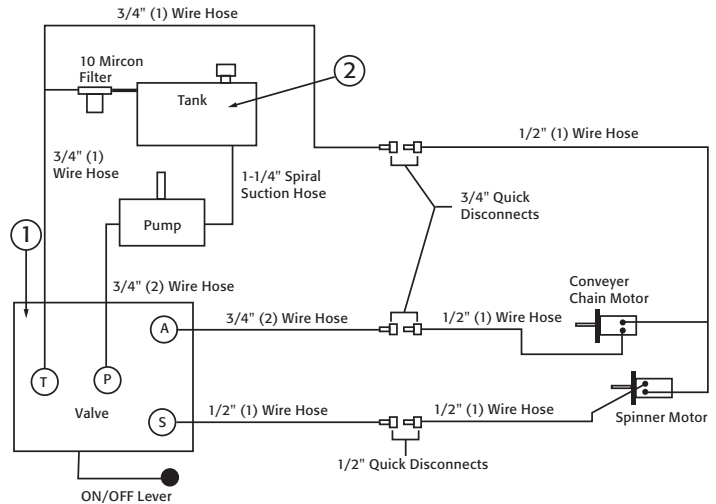

Valve Key
T= Tank/Reservoir
P= Pump/Pressure In
A= Auger (Conveyer Chain)
S= Spinner

(1) Single braid wire hose
(2) Double braid wire hose

Main Components

ITEM	PART NO.	QTY.	DESCRIPTION
1	HV715	1	Dual Flow Regulator Valve
2	-	1	Reservoir 25 Gal Min
N/S	HVC1	1	Dual Flow Regulator Console

2. Position valve on/off lever to off.

CAUTION

- Be sure everyone is standing clear of spreader.
- Be alert for anything that may require shutting down the system.
- Before working in or around spreader equipment, be sure all hydraulic controls are moved to off position.

3. Move auger (conveyor chain) and spinner knobs on the valve to the open position.

4. Engage PTO and circulate hydraulic oil for several minutes to warm up.

5. Move valve on/off lever to on.

6. Inspect hydraulic system for leaks.

7. Check conveyor chain and spinner to see if they are working properly and rotating the correct direction. To reverse rotation, switch the hydraulic lines at the motor.

8. Refill reservoir to 3/4 full.
9. Hydraulic system should now be ready for use.

Spreader Start-up

1. Check feed gate opening and baffle positions for desired material flow and spread pattern. See chute section.
2. Shut off spinner and auger (conveyor chain) knobs and position the on/off lever to on. Engage the PTO and allow the hydraulic system to warm up.
3. After the system is warm turn the spinner and auger (conveyor chain) knobs to the desired settings.
4. Changing the conveyor chain and spinner speeds as well as adjusting the baffle positions will produce various spread patterns.

Miscellaneous

1. Valve setting changes may be made with truck in motion.
2. By moving on/off lever to the off position, spinner and conveyor chain may be stopped at the same time without changing their valve settings.

Precautions – all models

- If the conveyor chain does not move because of dense material or a material jam, remove all material from the hopper and free the chain.

 **CAUTION**

Before working in or around spreader, the valve control lever must be in the off position. Disengage PTO and shut off engine.

 **CAUTION**

Position the valve on/off control lever in the off position when the spreader is not in use or is removed. In the event the valve on/off control lever is left in the on position, a heat problem may occur as the pump continues to pump oil to the hydraulic valve. This could cause a hose to burst spraying hot oil.

- If the material in the hopper freezes, move the

 **CAUTION**

Always follow the following precautions so as not to cause damage to the spreader.

spreader into a warm area to thaw.

- To prevent the feed chain from freezing, do not store material in the spreader.
- The gearbox is designed to only accept torque from the input shaft. Therefore, **DO NOT ATTEMPT TO FREE THE CONVEYOR BY USING A PIPE OR SIMILAR TOOL TO MOVE OR DISLodge THE CHAIN.** This action will void all warranties.
- Check and maintain the correct oil level for both the engine crankcase (gas models) and the gearbox (all models). The engine crankcase is filled with 1 quart of SAE 5W-30 motor oil at the factory. The gearbox is filled with SAE 90 gear lubricant at the factory.

Spreader Maintenance

- Use dielectric grease on all electrical connections before an electrical connection is made or after a connector is disconnected.

 **CAUTION**

The engine crankcase and gearbox must be filled and maintained with oil. The engine crankcase oil must be of the correct viscosity for the intended spreader operating conditions. Refer to the engine's owner manual to determine the correct viscosity. Operating the engine or gearbox without oil (or without a sufficient amount of oil) can cause permanent damage to the engine or crankcase.

- Grease the following components regularly:
 - Idler shaft bearings (2)
 - Drive shaft bearings (2)
 - Spinner shaft bearings (2)
 - Flanged bearing located between gearbox and clutch (gas models only).
 - Gearbox input shaft (if equipped with fitting)
- Check gearbox oil level periodically and maintain the oil level by adding appropriate lubricant.
- (Gas engine models) Fill the engine crankcase with recommended oil to the full line. Read the engine owner's manual for the recommended oil viscosity for

your operating conditions. Check the oil level periodically and maintain the oil level. Clean and lubricate engine's choke throttle linkage.

1. Check the Feed Chain tension periodically.

To check the tension, measure in 21"-25" from the rear edge of the sills. Push up on the chain with your hand. The conveyor chain should lift up 2"-3" off the conveyor chain guide or cross angles.

2. Maintain the correct tension on the following roller chains – Gas Powered Models

- Chain A - Engine to gearbox input sprocket.
- Chain B - Spinner shaft to gearbox input

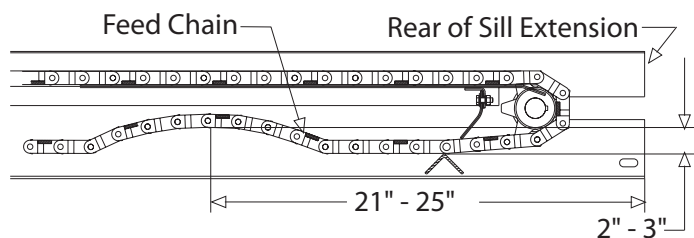

sprocket.

- The correct chain tension allows 5/16" deflection midway between respective sprockets. Oil both roller chains often, and at the end of each season.
- To loosen or tighten Chain A: loosen the four (4) 3/8-16 X 1 carriage bolts that fasten the engine mount stand to the engine deck and slide the engine mount stand.
- To loosen or tighten Chain B: First, loosen the spinner chute fasteners and slide the spinner/chute assembly. If additional adjustment is needed, loosen the spinner shaft bearing bolts and slide the spinner shaft. Be sure to maintain the vertical alignment of the spinner shaft and bearings before tightening the hardware.
- Empty the spreader of all ice control material when not in use to prevent a frozen feed chain & damage due to corrosion.
- Wash out the spreader when it is not in use. At the end of the season wash out the spreader to remove all ice control materials. Thoroughly dry all metal sur-

⚠ CAUTION

Do not over-tension the roller chain. This can cause damage to the chain, bearings, and gearbox.

faces. Re-paint and oil all previously painted surfaces and chains to protect from rust. Properly store the spreader for the next season.

3. To minimize problems & extend the life of the gas engine & electric clutch, the following procedures are recommended:

- Maintain the spreader engine according to the engine owner's manual. This manual is shipped with the spreader. The engine warranty is covered by the engine's manufacturer. If engine service is required, contact an authorized service center for the engine's manufacturer.
- At the end of the season, remove and clean the electric clutch.
- After cleaning, coat both mating surfaces of the clutch with oil or light grease.
- Remove oil and grease prior to using the clutch again.

Spreader Maintenance - Hydraulic Models

- 1.** Warm up hydraulic system before using.
- 2.** Keep the reservoir 3/4 full with high grade non-foaming hydraulic oil.
- 3.** Use precautions to keep contaminants from getting in reservoir when filling.
- 4.** Quick connects are a prime source of contamination.
 - Clean quick connects before connecting or disconnecting them.
 - Protect quick connects from contaminants at all times.
- 5.** Lubricate all bearings with suitable type grease on a regular basis. More frequent lubrication is recommended during periods of heavy use.
- 6.** Maintain the proper lubrication level in all gearboxes with SAE 90 gear lubricant.
- 7.** When not in use, keep the spreader empty to prevent freezing of material in the hopper in extremely cold weather.
- 8.** To extend the life of your spreader:
 - Hose down and clean after each use.
 - Repaint and/or oil after each season.

Throttle Motor Assembly Instructions -Gas Powered Models

(diagram on pg. 12)

1. Removal Instructions:

- Carefully observe the existing installation and mark the position of the throttle control bracket on the en-

gine mount stand.

- Disconnect the wire connections.
- Remove the 1/4-20 fasteners that hold the throttle control bracket to the engine mount stand. Remove the throttle motor assembly.

CAUTION

Improper installation of the throttle motor assembly can result in damage to the engine choke/throttle linkage.

2. Installation Instructions:

- Connect the electrical wiring. Be sure to connect the brown wire to brown wire and red wire to red wire.
- Run the new throttle motor until the crank is within opening of the throttle control bracket.
- Fasten the new throttle motor to the throttle control bracket using the original hardware.
- Place the throttle pin assembly on the crank of the throttle motor using hole in the middle of plastic block.
- Place the assembly onto the engine mount stand by inserting the throttle pin into the engine choke/throttle linkage slider.
- Keeping the throttle pin assembly parallel to the engine choke/throttle linkage bolt the assembly to the engine mount stand with the existing hardware.
- Run throttle motor in both directions until the slider in choke/throttle linkage stops against choke/throttle linkage bracket. Adjust position of throttle bracket if necessary.

Options & Accessories

PART NO.	DESCRIPTION
3008560	Dumpbody Tailgate Latch Kit, Universal
LB8443SST	Stainless Steel D.O.T. Spreader Lightbar, 7-hole round light box (8" x 3" x 44")
LB8663SST	Stainless Steel D.O.T. Spreader Lightbar, 9-hole round light box (8" x 3" x 66")
LS1	12-Volt Liquid Spray, 55 gal. poly reservoir (not for 1400475SS, 1400475SSH)
LS3	12-Volt Liquid Spray, (2) 55 gal. poly reservoirs (not for 1400475SS, 1400475SSH)
LS4	12-Volt Liquid Spray, 105 gal. poly reservoir
LS5	12-Volt Liquid Spray, (2) 105 gal. poly reservoirs

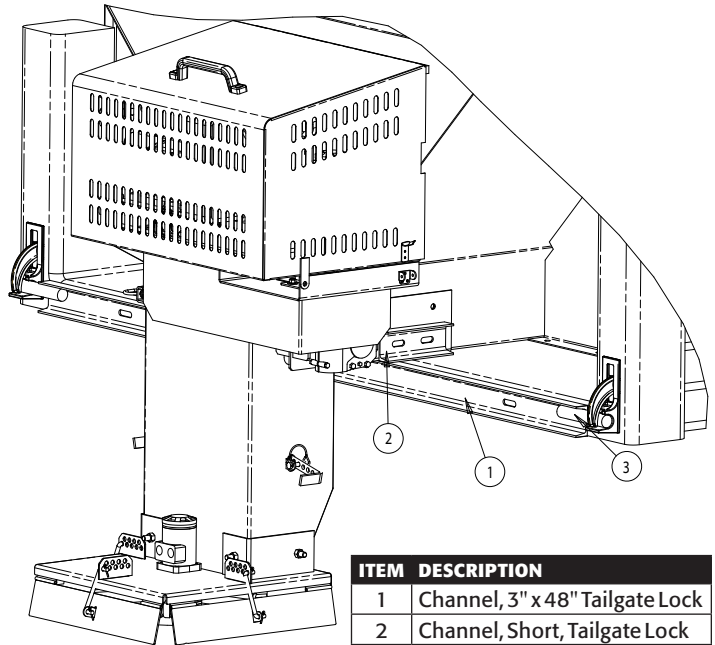

3008560

ITEM	DESCRIPTION
1	Channel, 3" x 48" Tailgate Lock
2	Channel, Short, Tailgate Lock
3	Shaft, Tailgate Lock



LB8443SST

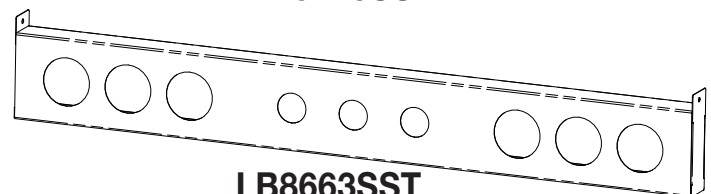

LB8663SST

Drive System *(drawing on pg. 11)*

ITEM	PART NO.	QTY.	DESCRIPTION
1	3008311	1	Hopper 108" SST
1	3009196	1	Hopper 120" SST
1	3014449	1	Hopper 3 Cu. Yd. SST
1	3025240	1	HOPPER 10 FT 3.0 CU YD SST - 1400465SS
1	3028138	1	HOPPER 9 FT 2.75 CU YD SST - 1400460SS
1	3028151	1	HOPPER 8 FT 2.5 CU YD SST - 1400455SS
2	3009199	1	SHIELD, 10' TROUGH PS
2	3008353	1	SHIELD, 9' TROUGH PS
2	3014540	1	SHIELD, 8' TROUGH PS
2	3024546	1	SHIELD, 10' TROUGH DS
2	3024539	1	SHIELD, 9' TROUGH DS
2	3024535	1	SHIELD, 8' TROUGH DS
3	3008359	1	Inverted Vee 9'
3	3009201	1	Inverted Vee 120"
3	3014543	1	Inverted Vee 3 Cu. Yd.
3	3025254	1	INVERTED VEE, 10 FT - 1400465SS
3	3028141	1	INVERTED VEE, 9FT - 1400460SS
3	3028160	1	INVERTED VEE, 8FT - 1400455SS
4	3014538	1	Tray, Conveyor Floor, 3 Cu. Yd.
4	3009197	1	PAN, 10' CONVEYOR FLOOR
4	3008301	1	PAN, 9' CONVEYOR FLOOR
4	3028159	1	PAN, 8' CONVEYOR FLOOR - 1400455SS
5	3008352	4	Grate, Welded Top 9'
5	3009206	4	Grate, Welded Top 10'
5	3014545	4	Grate, Welded, 3 Cu. Yd.
5	3025436	2	TOP SCREEN HALF, 10FT - 1400465SS

ITEM	PART NO.	QTY.	DESCRIPTION
5	3028143	2	TOP SCREEN HALF, 9FT - 1400460SS
5	3028154	2	TOP SCREEN HALF, 8FT - 1400455SS
6	3008894	1	Deck, Engine, Welded
7	3008289	1	Coupling, Drive Shaft/Gearbox
8	1410803	2	Pin, Clevis, 3/8 x 2, 1038 ST, ZN yellow
9	3008294	2	Bearing Flanged
10	3008300	4	Sprocket, D667H Conveyor
11	3008316	1	Shaft, Sprocket Drive End
12	KS402	3	Key, 1/4 x 1/4 x 2
13	3014539	1	Chain, 8' Conveyor
13	3008860	1	Chain, 9' Conveyor
13	3009114	1	Chain, 10' Conveyor
14	3008317	1	Shaft, Idler Sprocket
15	3008290	2	Bearing, Heavy-Duty Take-Up
16	3004278	2	Screw, BTN. HD Socket Cap 1/2-13, SST
17	3001523	6	Nut, HX FLNG 1/2-13, SST
18	3001522	4	Bolt, Carriage 1/2-13 x 1, SST
19	141050WSS	2	Bolt, Welded Take-Up, SCH Idler
20	FNH063011054SS	2	Nut, 5/8-11 UNC THD, SST
21	FCS038016100SS	8	Screw, HHC 3/8-16 x 1, 304 SST
22	FNE038016044SS	8	Nut, Nylock 3/8-16 x 7/16, SST
23	3011832	1	Lever, Welded, Feed Gate
24	3008339	1	Bar, Feed Gate
25	3008338	1	Door, Salt Gate
26	3003874	1	Nut, 1/2-13 Heavy Hex, SST

Drive System (bill of materials on pg. 10)

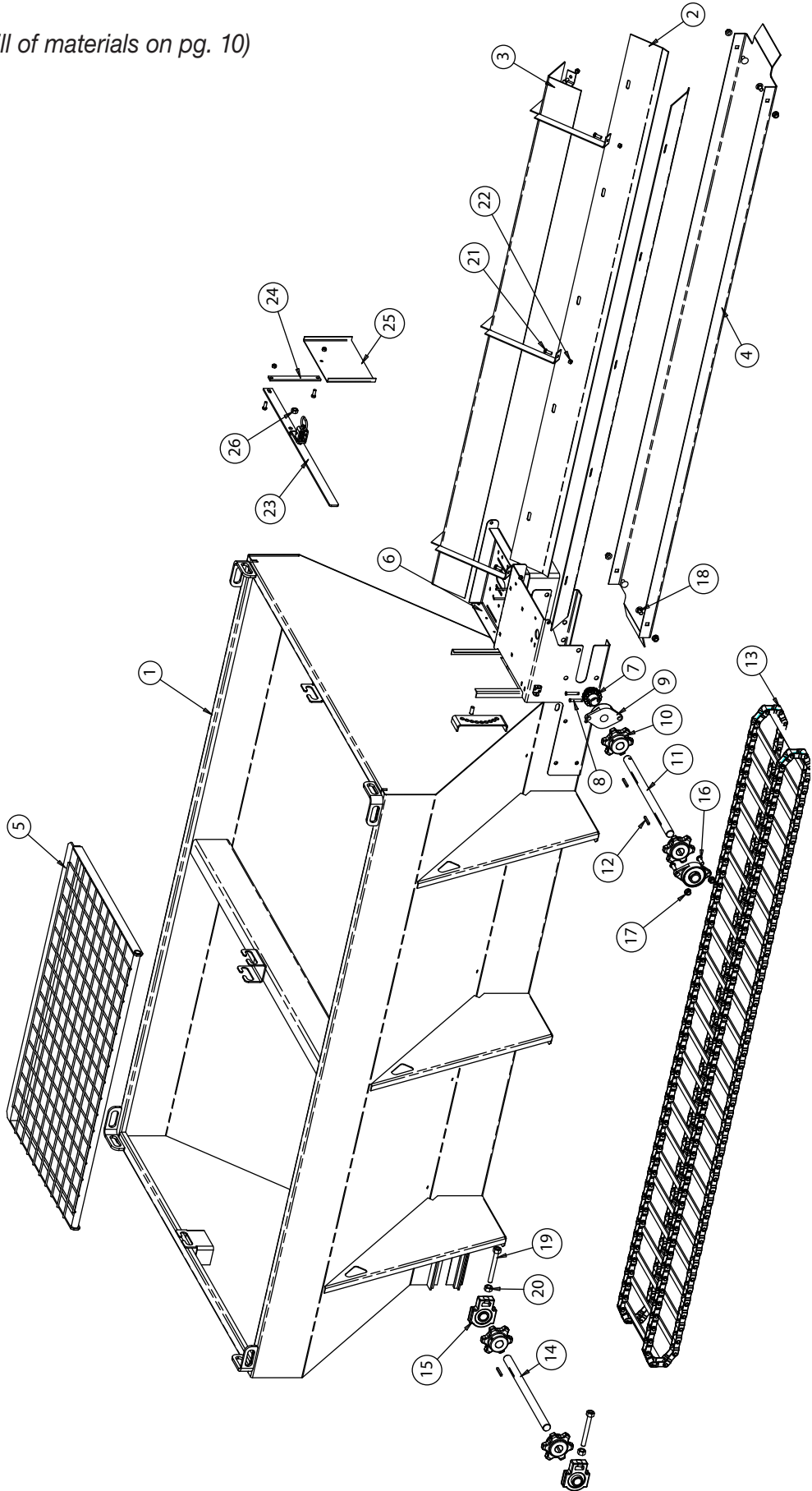

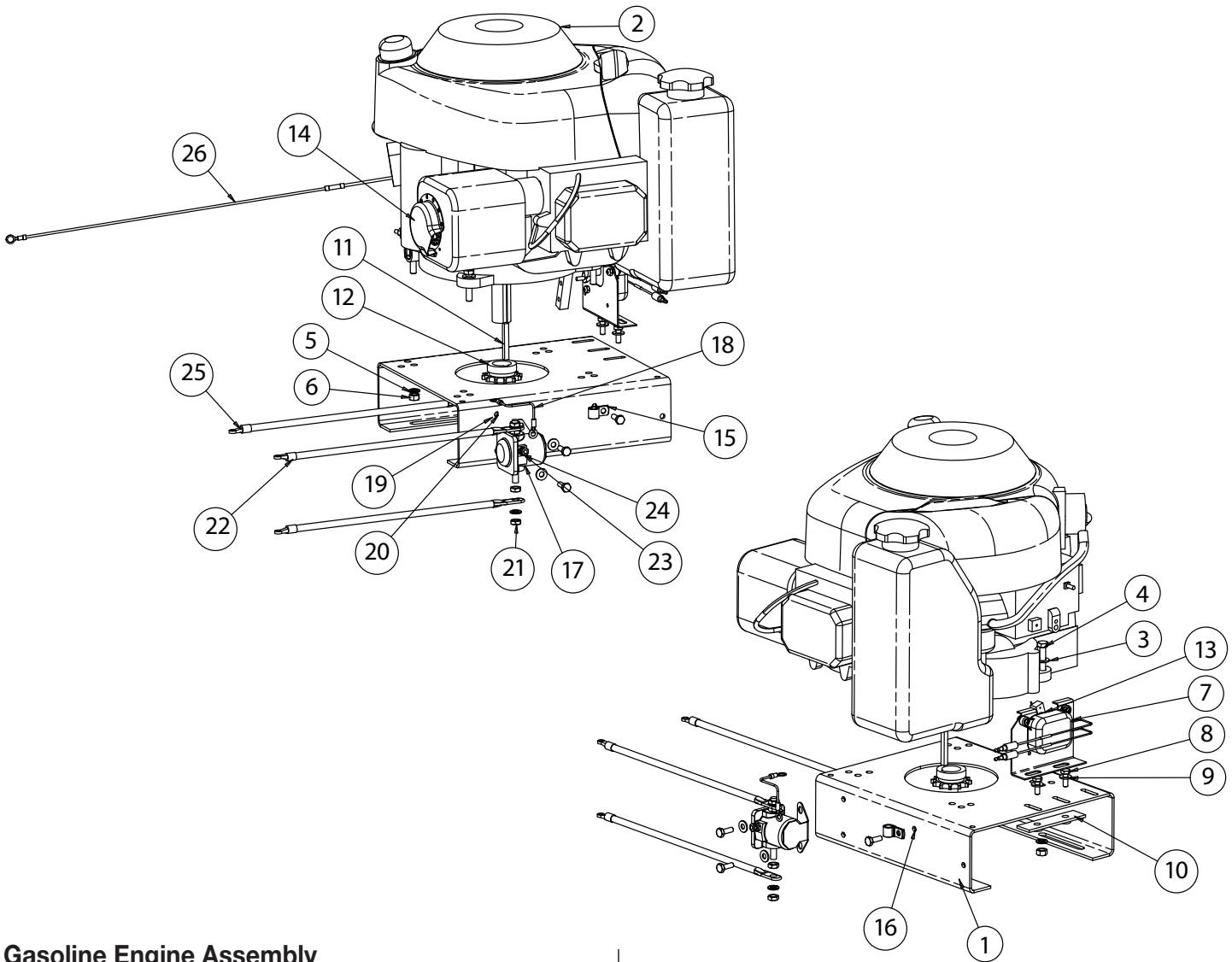

Gasoline Engine Assembly

ITEM	PART NO.	QTY.	DESCRIPTION
1	3008326	1	Stand, Engine Mount
2	3006887	1	Engine, 9 (10.5) HP Briggs, w/ Recoil & Fuel Tank
3	-	4	Washer, 5/16 SAE, ZN
4	-	4	Screw, HHC 5/16-18 x 1.5 Gr. 5, ZN
5	-	6	Washer, Spring Lock, 5/16 ZN
6	-	4	Nut, 5/16-18 Hex, ZN
7	3003231	1	Throttle Control
8	-	5	Screw, Cap 1/4-20 x 3/4 SST
9	-	4	Washer, Flat 1/4 SAE, ZN clear
10	1411911	1	Retainer, Throttle Motor Kit
11	KS402	1	Key, 1/4 x 1/4 x 2
12	1411915	1	Sprocket, Engine Drive
13	1411910	1	Throttle Pin, Assembly

ITEM	PART NO.	QTY.	DESCRIPTION
14	3006887A	1	Deflector, Exhaust (comes with engine)
15	4375	1	Clamp, Hose .4375, 9/32 ZN
16	-	1	Nut, Nylon Insert 1/4-20 ZN
17	1306070	1	Solenoid, Motor
18	3007679	1	Wire Harness Ground
19	-	2	Washer, 1/4" Spring Lock
20	-	2	Nut, Hex 1/4-20 ZN
21	-	4	Nut, Jam 5/16-24 ZN
22	3001379	2	Cable, SCH Battery 14" red
23	-	2	Nut, Hex 10-32 ZN yellow
24	-	1	Washer, #10 Split Lock, ZP
25	3001378	1	Cable, SCH Battery 14" black
26	3006922	1	Wire Assy., Voltage Regulator, 9HP B&S

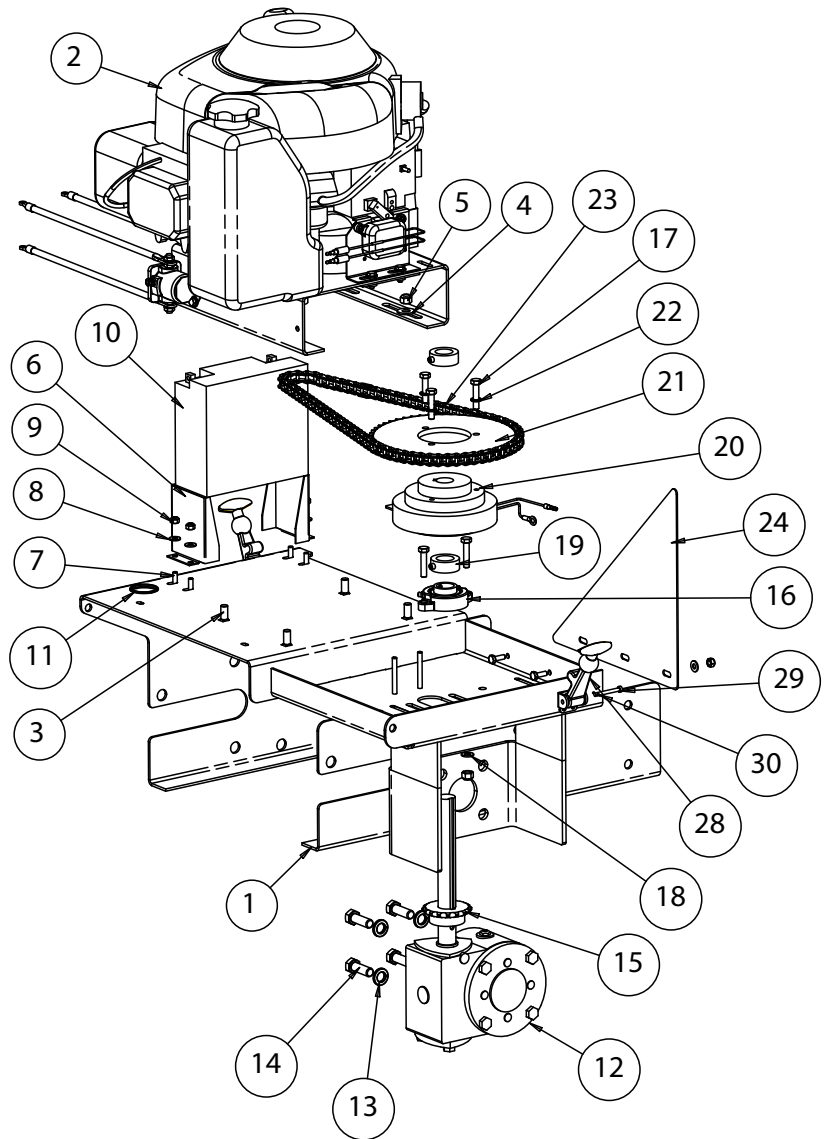
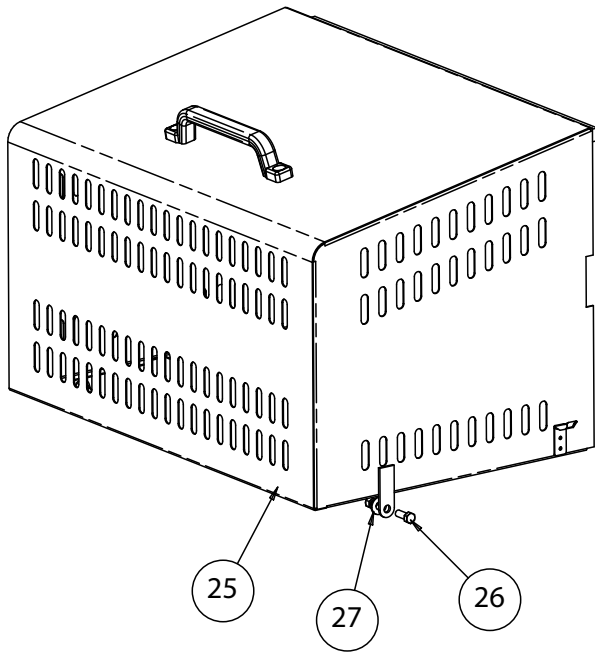

Gasoline Engine & Deck Assembly

ITEM	PART NO.	QTY.	DESCRIPTION
1	3008894	1	Deck, Engine, Welded
2	3008327	1	Engine Assembly
3	-	4	Bolt, 3/8-16 x 1 Carriage, SST
4	-	4	Washer, Flat 3/8 USS SST
5	-	8	Nut, Nylock 3/8-16 x 7/16, SST
6	3001363	2	Bracket, Battery Mount
7	-	7	Screw, Cap 1/4-20 x 3/4 SST
8	-	7	Washer, Flat 1/4 SAE, ZN clear
9	-	7	Nut, Nylon Insert 1/4-20, SST
10	1410717	1	Battery, 12V, 20AMP, 275CCA SLA
11	1413200	1	Grommet, 1-1/2 Rubber
12	1411200	1	Gearbox
13	-	4	Washer, Lock, 1/2 Split, SST
14	-	4	Screw, HHC 1/2-13 x 1, SST
15	1410702	1	Sprocket, Gearbox Spinner Chain
16	1411000	1	Bearing, 2-Hole Flanged 1"
17	-	5	Screw, HHC 5/16 SAE, ZN

ITEM	PART NO.	QTY.	DESCRIPTION
18	-	2	Washer, 5/16 SAE, ZN
19	1411500	2	Collar, Locking w/ Setscrew
20	1401150	1	Assembly, Clutch
21	1411800	1	Sprocket, Clutch Chain
22	-	3	Washer, Spring Lock, 5/16 ZN
23	3009112	1	Chain, #40 Roller, 88 Pitches
24	3002113	1	Guard, Engine Base, SST
25	3008333	1	Shroud Engine, SST
26	-	2	Screw, HHC 3/8-16 x 1, 304 SST
27	3001361	2	Washer, 3/8 Nylon, Flat
28	3002398	2	Strap, Hood Latch
29	3002390	2	Pin, Clevis 3/16" x 1-11/16", SST
30	3002392	2	Pin, Cotter 1/16" x 1/2", SST
31	1499025	1	Label, Warning 2 (gasoline)
32	1499050	1	Label, Caution 2
33	3009653	1	Harness 3' Hopp. Spr.

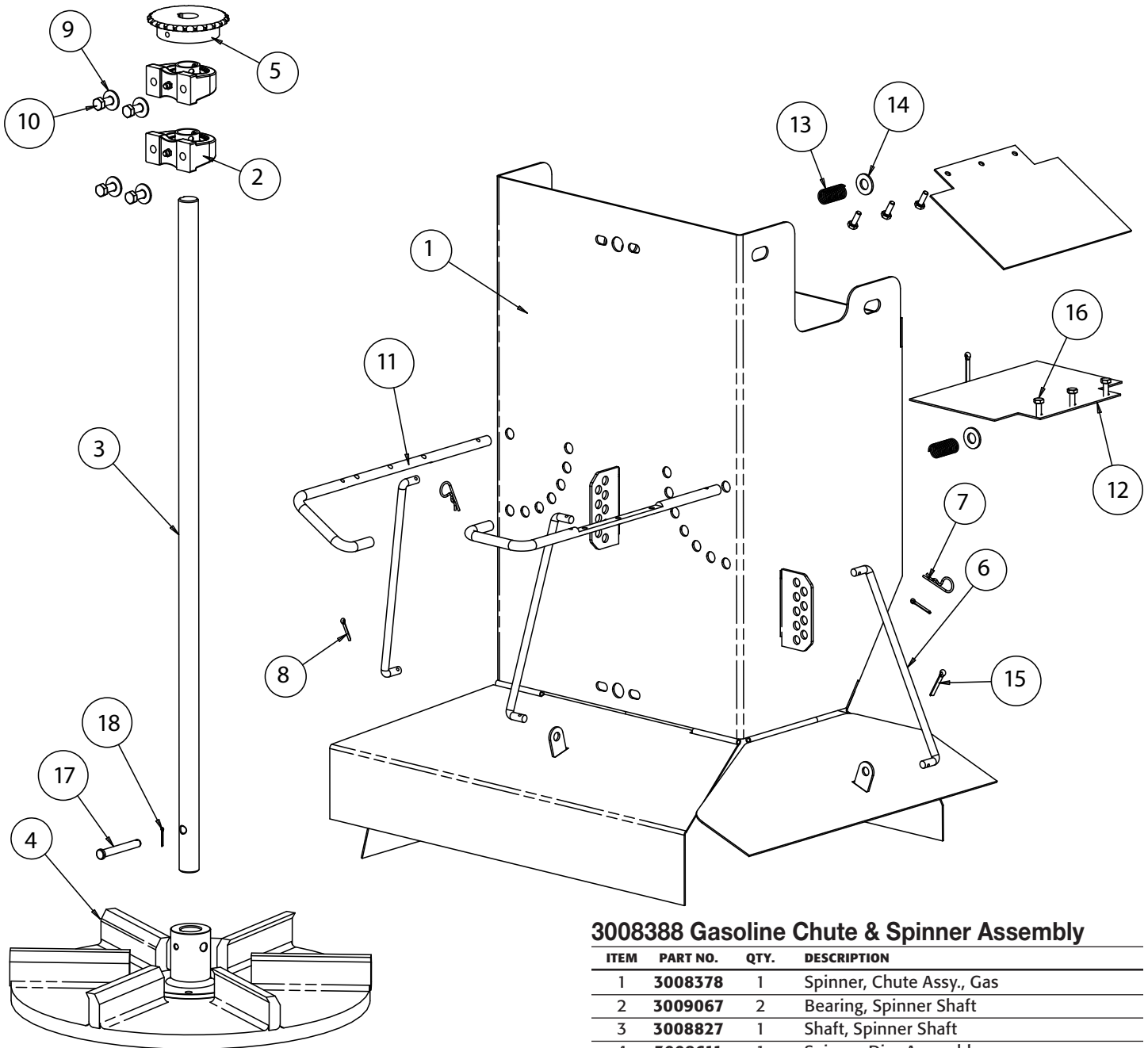

3008388 Gasoline Chute & Spinner Assembly

ITEM	PART NO.	QTY.	DESCRIPTION
1	3008378	1	Spinner, Chute Assy., Gas
2	3009067	2	Bearing, Spinner Shaft
3	3008827	1	Shaft, Spinner Shaft
4	3008611	1	Spinner Disc Assembly
5	3008835	1	Sprocket, 24 Tooth, #40 R Chain
6	1420015	3	Control Rod, SCH Chute
7	1420016	3	Pin, Hair Cotter, ZN clear
8	-	3	Cotter Pin, 1/8 x 1, ZN
9	-	4	Washer, Flat 3/8 USS, SST
10	-	4	Screw, HHC-3/8-16 x 3/4 SST
11	3008852	2	Rod, Selector
12	3008396	2	Deflector, Inside
13	3008853	2	Spring, Spinner Chute Baffle
14	-	2	Washer, Flat 1/2" SAE, ZN
15	-	2	Pin, Cotter 3/16" x 1.25", ZN
16	-	6	Screw, Cap 1/4-20 x 3/4, SST
17	3009632	1	Pin, Clevis 3/8 x 2.5 UL
18	-	1	Cotter Pin, 5/64 x 3/4
19	3009327	1	Chain #40 Spinner Drive

Hydraulic Motor & Deck Assembly

ITEM	PART NO.	QTY.	DESCRIPTION
1	3008894	1	Deck, Engine, Welded
2	1401200	1	Gearbox
3	3008634	1	Stand, Hydraulic Motor
4	-	4	Screw, Cap 1/4-20 x 3/4, SST
5	-	4	Washer, Flat 1/4 SAE, ZN clear
6	-	4	Nut, Nylon Insert 1/4-20, SST
7	3009305	1	Motor, Hydraulic white
8	-	4	Screw, HHC 3/8-16 x 3/4, SST
9	-	4	Washer, Lock RHS 3/8, SST
10	3009215	1	Coupling, Shaft 1 x 1
11	-	4	Washer, Lock 1/2 Split, SST
12	-	4	Screw, HHC 1/2-13 x 1, SST
13	3002398	2	Strap, Hood Latch
14	3002390	2	Pin, Clevis 3/16" x 1-11/16", SST
15	3002392	2	Pin, Cotter, 1/16" x 1/2" SST
16	3009619	2	Cover, Coupler

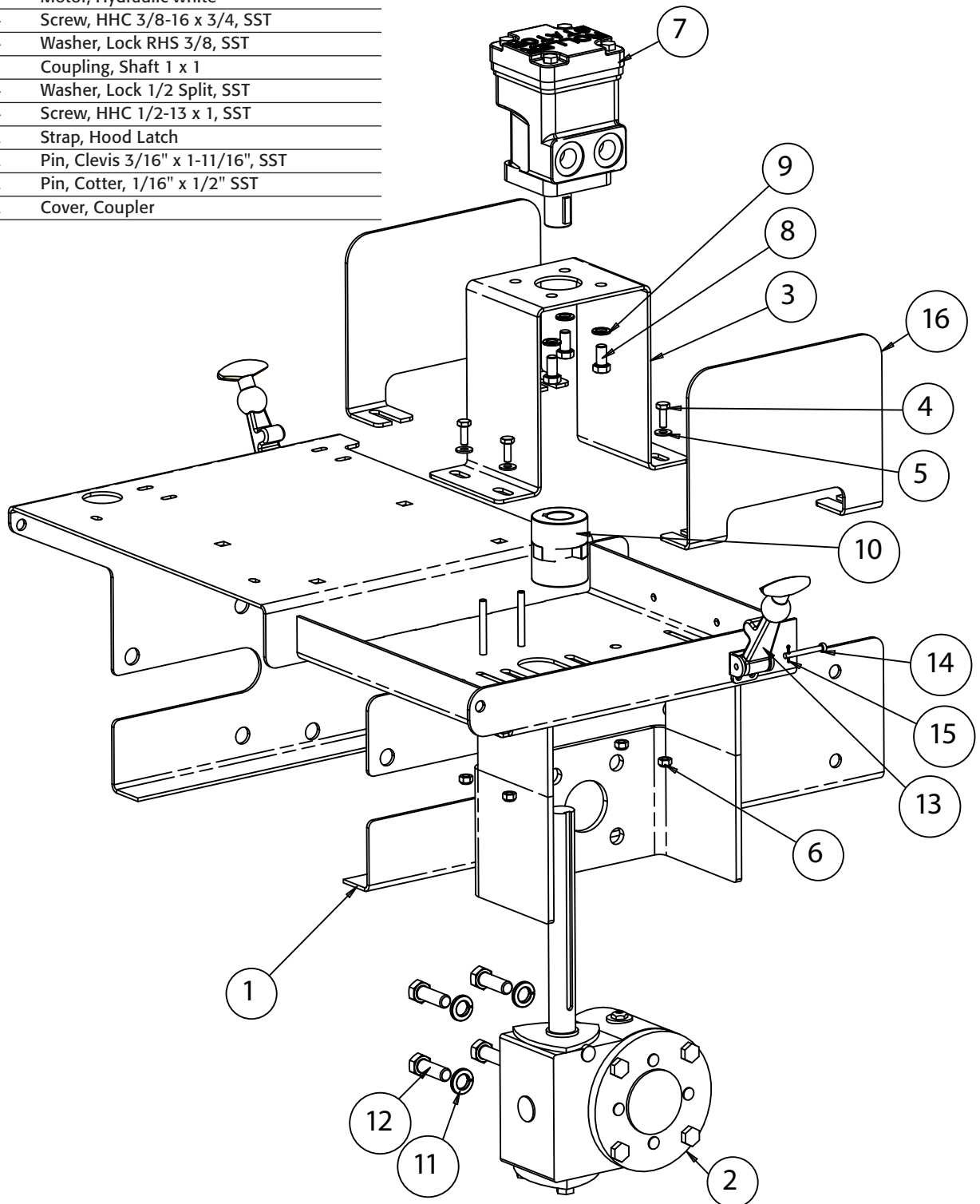

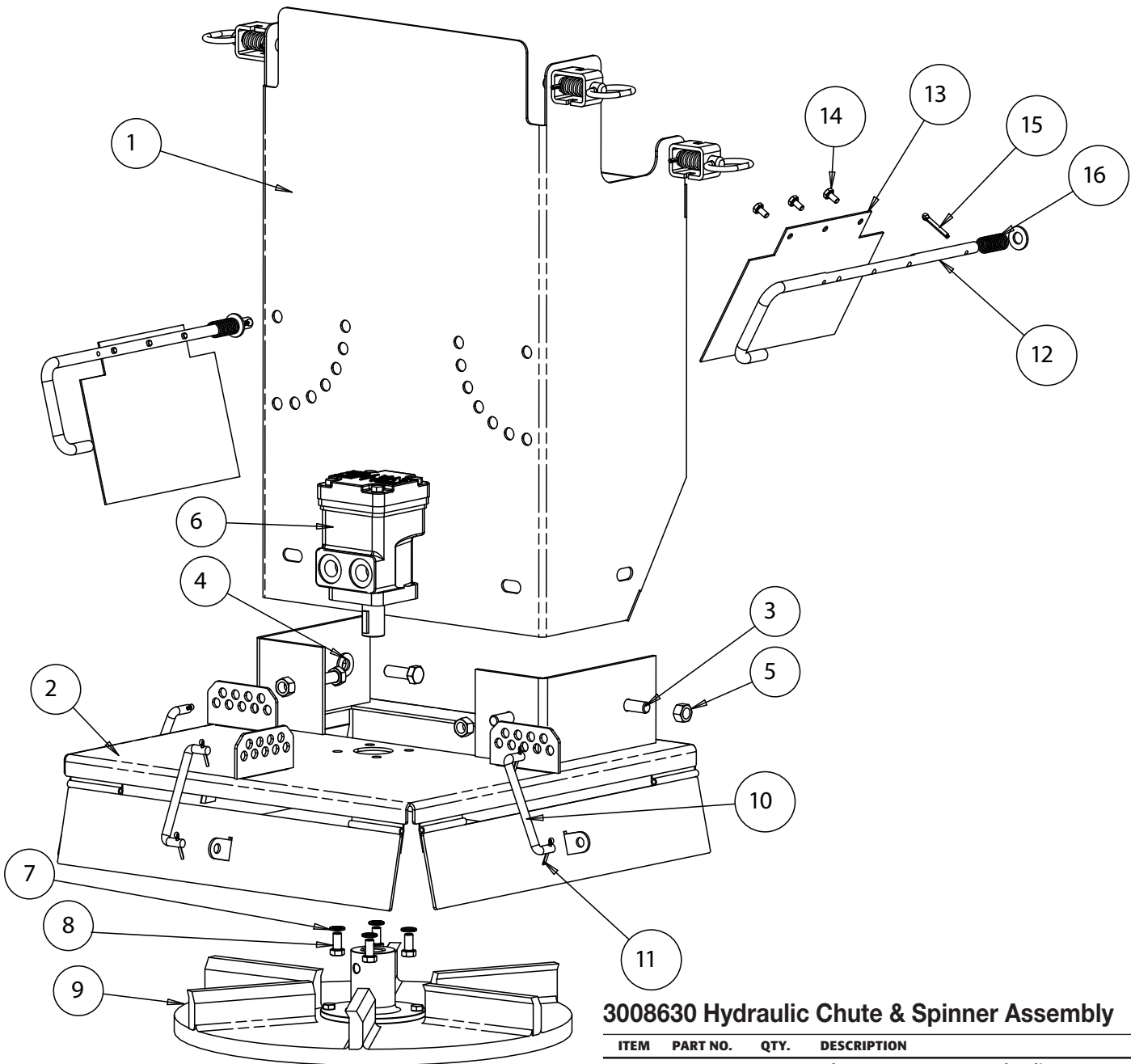

3008630 Hydraulic Chute & Spinner Assembly

ITEM	PART NO.	QTY.	DESCRIPTION
1	3008612	1	Chute, Upper Assy., Hydraulic
2	3008624	1	Chute, Lower Assy., Hydraulic
3	-	4	Screw, HHC-1/2-13 x 1, SST
4	-	6	Washer, Flat 1/2 SAE, ZN
5	-	4	Nut, Hex 1/2-13, SST
6	3009305	1	Motor, Hydraulic white
7	-	4	Washer, Lock RHS 3/8, SST
8	-	4	Screw, HHC-3/8-16 x 3/4 SST
9	3008611	1	Disc, Spinner Assembly
10	3008628	3	Control Rod, Hydraulic Chute
11	-	2	Pin, Cotter 1/8" x 1", ZN
12	3008852	2	Rod, Selector
13	3008396	2	Deflector, Inside
14	-	6	Screw, Hex HD Cap 1/4-20 x 1/2, ZN
15	-	2	Pin, Cotter 3/16" x 1.25", ZN
16	3008853	2	Spring, Spinner Chute Baffle