

# Assembly Instructions

## WB150BG Heavy-Duty Carbon Steel Walk Behind Salt Spreader, Bulk Flow Gate

## WB250BG Heavy-Duty Stainless Steel Walk Behind Salt Spreader, Bulk Flow Gate

Check contents of box against the parts list to make sure all components are included. When ordering replacement or spare parts refer to the parts list for part numbers.

### TOOLS NEEDED FOR ASSEMBLY

- (2) 10mm Wrenches
- (2) 1/2 in Wrenches

### Attaching the Handle, Linkage Plate Assembly, and Lower Linkage – Figures 2 – 6

**A.** Remove contents from box and place the preassembled portion of the spreader upright on its wheels

**B.** Slide the Handle onto the spreader frame & line up the holes

**C.** Carefully insert the Lower Linkage into the Restrictor Plate underneath the Hopper as shown. (The Lower Linkage has two bent ends & the Upper Linkage has one threaded end)

**D.** Insert the other end of the Lower Linkage into the front hole on the Linkage Plate Assembly

**E.** Attach the Linkage Plate Assembly and Handle to the Frame using two M6x40 bolts as shown. Figure 6 shows the lower linkage assembled (for reference).

**NOTE:** The Lower Linkage must be attached to the restrictor and the Linkage Plate Assembly before the Assembly is attached to the frame. If the Linkage Plate Assembly is attached to the Frame without the Lower Linkage, the Lower Linkage will be very difficult to assemble and may cause the restrictor plate to be broken during assembly

### Attach Control Handle Assembly, Upper Linkage, & Rear Deflector – Figure 7 & 8

**F.** Mount the Control Handle Assembly to the Handle using two M6x40 bolts as shown.

**G.** Insert the Upper Linkage into the Control Handle as shown.

**H.** Thread one Jam Nut so that the Restrictor Plate underneath the Hopper is fully closed when the Control Handle is at "30". Assemble the second jam nut in this position to lock the linkage in place.

**I.** Verify that the Restrictor Plate may be fully opened by pushing the Control Handle forward.

**J.** Using two M6x20 bolts, attach the rear deflector.



### Final Assembly

**A. Check And Tighten All Fasteners** – Make sure the Gearbox turns freely when pushing and pulling the unit.

**B.** Place the Screen in the hopper.

**C.** Install the Rain Cover on the hopper.

### Operation

**1.** Before filling Hopper, ensure that the Restrictor Plate is fully closed and the screen is in place.

**2.** Move and tighten the stop bolt to the desired setting.

**3.** Begin moving forward with the spreader.

**4.** Pull the Control Handle back to the stop bolt to open Restrictor Plate and allow material to flow.

**5.** Before stopping, push the Control Handle fully forward to stop flow.

### Maintenance

**1.** The Hopper and Spinner should be completely emptied and cleaned before storage.

**2.** The Spreader should be washed and dried before storage.

**3.** Check that the Restrictor Plate and Linkage move freely. Clear out any debris between the Restrictor Plate & the Hopper.

**4.** Check that there is no debris in the Gears & that they move freely.

**5.** Check torque of all fasteners on a monthly basis.

### Operation Notes:

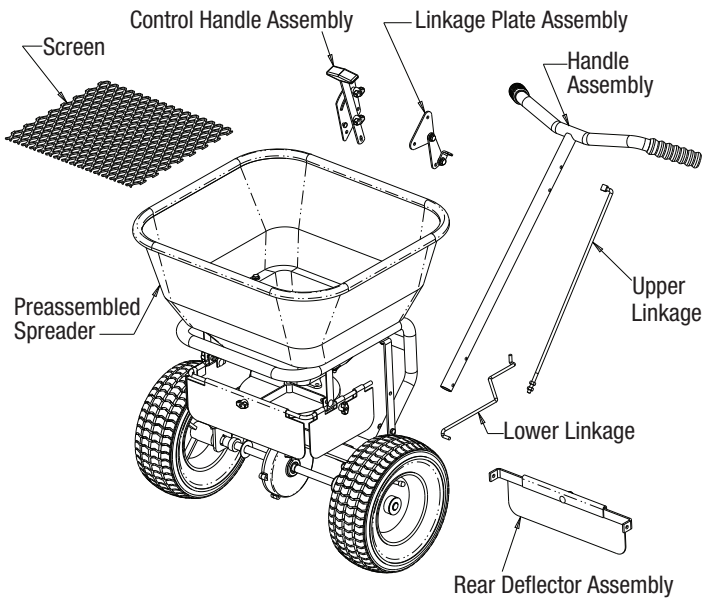
**1.** The spreader is designed to be operated at a brisk walking pace (approx. 3mph). Walking slower or faster will alter the distribution pattern & amount of the material, as will the moisture content of the material & other environmental factors.

**2.** Grease may be applied to the Gearbox as desired.

### WARNING

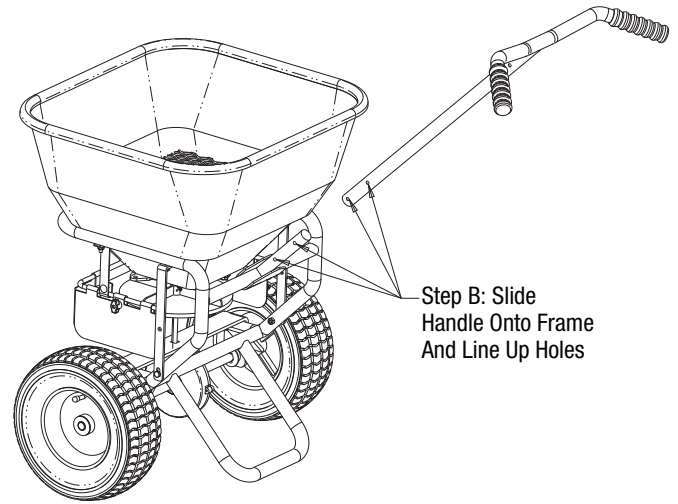
When filling hopper, make certain there are no large objects within the material. Objects larger than the openings in the Screen may cause the spreader to clog or even damage the drive system. Never leave material in the hopper when not in use.

**Figure 1 - Contents of Box**

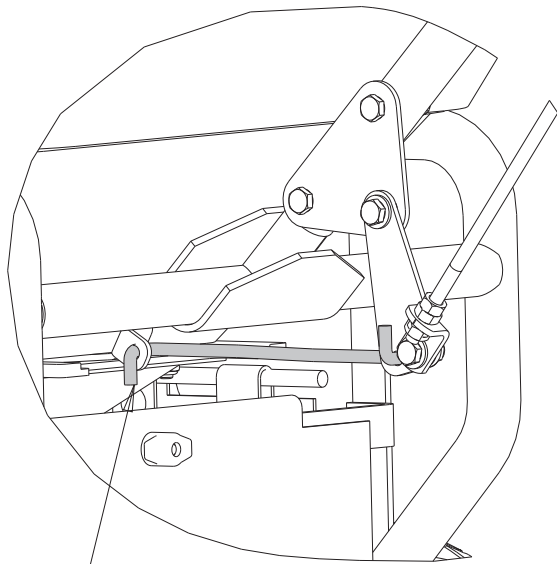


Rain Cover And Hardware Kit Are Not Shown

**Figure 2**

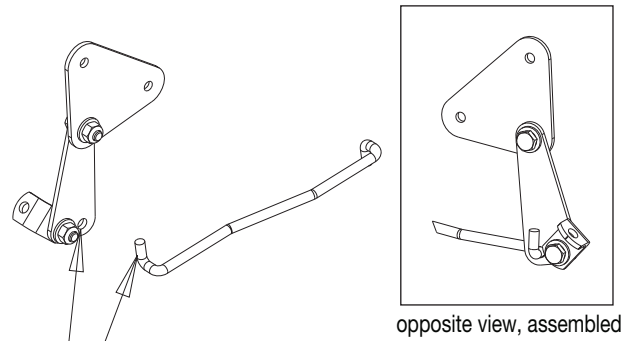


**Figure 3**



**Step C:**  
Insert Lower Linkage Into Restrictor Plate and Rotate To This Position

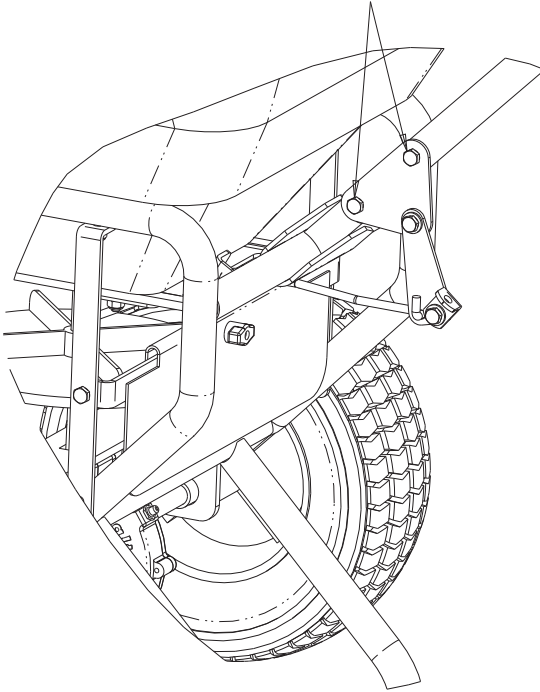
**Figure 4**



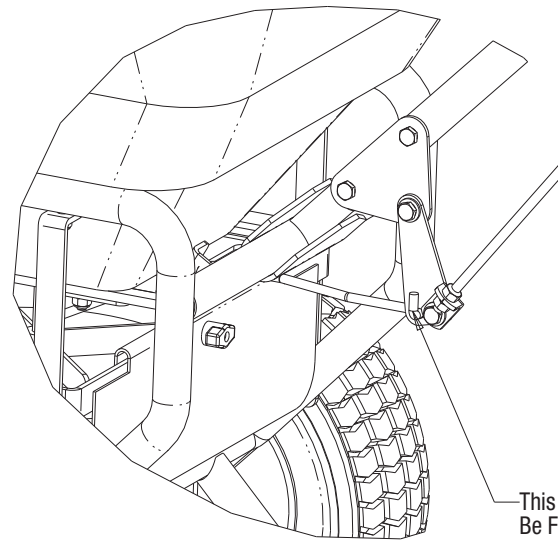
**Step D:**  
Place Linkage Plate Assembly Over End of Lower Linkage as Shown in Inset

**Figure 5**

E. Attach Control Plate Assembly To Frame Using M6x40 Bolts

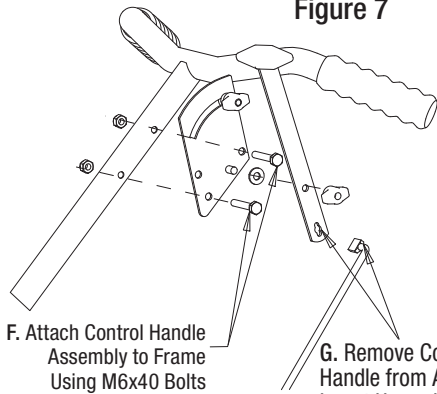


**Figure 6**



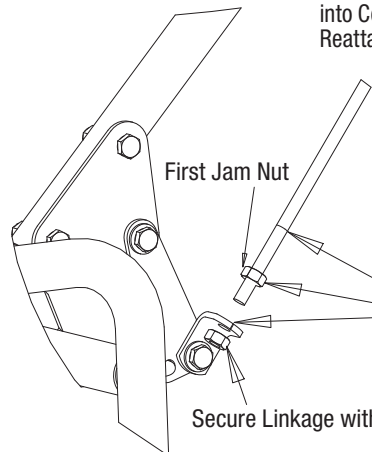
This End of Rod To Be Facing Upward

**Figure 7**



F. Attach Control Handle Assembly to Frame Using M6x40 Bolts

G. Remove Control Handle from Assembly, Insert Upper Linkage into Control Handle, Reattach Control Handle

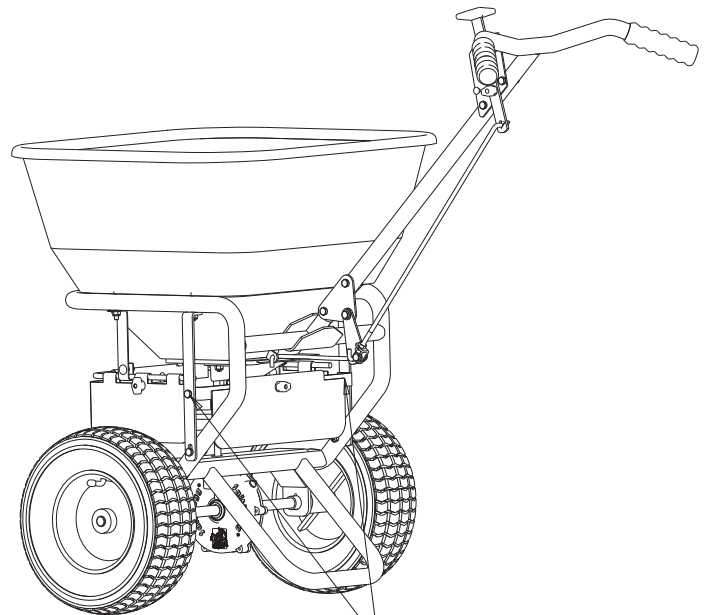


First Jam Nut

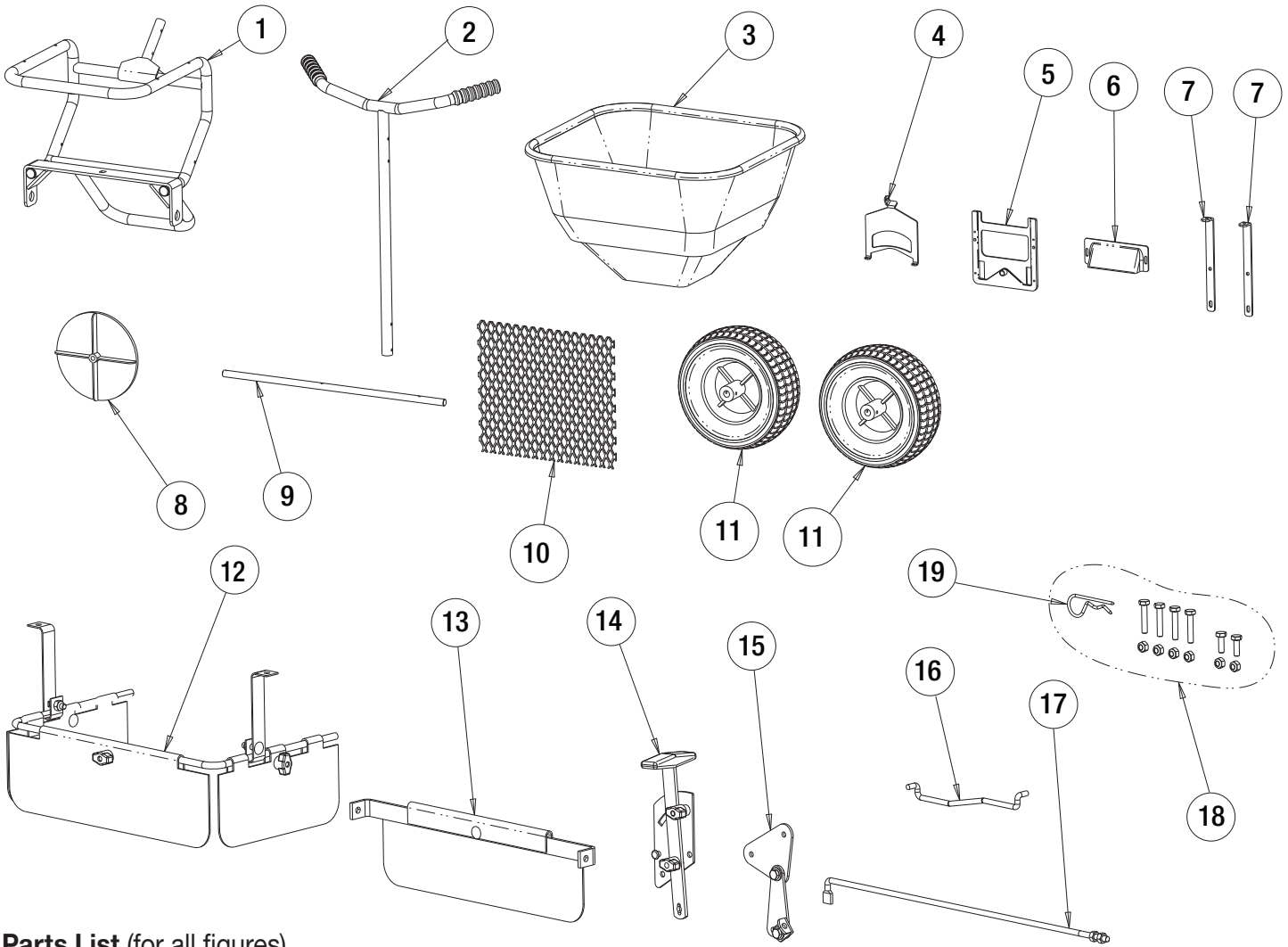
H. Thread First Jam Nut onto Upper Linkage and Insert Linkage into Control Plate Assembly

Secure Linkage with Second Jam Nut and Tighten

**Figure 8**



J. Attach Rear Deflector Using M6x20 Bolts



**Parts List (for all figures)**

ITEM	WB150BG (STEEL)	WB250BG (STAINLESS)	QTY	DESCRIPTION
1	3021435	3024672	1	Frame
2	3010874	3011730	1	Handle
3	3033383	3033383	1	Hopper
4	3033384	3033384	1	Restrictor
5	3033385	3033385	1	Guide,Restrictor
6	3033235	3033235	1	Chute
7	3010871	3011741	2	Hopper Support Bracket
8	3012696	3012696	1	Spinner Disc
9	3035272	3035273	1	Axle
10	3008813	3008813	1	Screen
11	3014857	3014857	2	Wheel
12	3008142	3011733	1	Deflector Assembly
13	3011734	3011735	1	Rear Deflector Assembly
14	3009160	3011736	1	Control Handle Assembly
15	3010878	3011737	1	Linkage Plate Assembly
16	3033387	3033395	1	Lower Linkage
17	3010880	3011738	1	Upper Linkage
18	3015357	3015357	1	Hardware Bag
19	3007873	3007873	1	Agitator Pin
20	3012704	3012704	2	Axle Bushing
21	3027118	3032800	1	Gearbox Assembly

**FULL ONE YEAR WARRANTY**

Manufacturer will repair, or at manufacturer's discretion will replace any part of this salt spreader which proves to be defective in workmanship or material under normal use for a period of one year from the date of delivery to the original purchaser. Any cost incurred in returning the product to the supplier is the responsibility of the consumer.

**EXCLUSIONS**

Manufacturer shall not be liable for special, incidental, or consequential damages, or for damages resulting from lack of necessary maintenance, from misuse, abuse, acts of God, or alteration of the product. Some states do not allow the exclusion or limitation of incidental or consequential damages, so the above limitation or exclusion may not apply to you.